



# SkyWay® 7000 Series Multipoint Client Unit User's Guide

*For SkyWay 7100, 7300, and 7500*

October, 2005  
Version 2.0

## 1. Introduction

Congratulations on your purchase of Solectek's SKYWAY 7000 Series Bridge/Router Multipoint Client Unit, a feature rich, best-in-class wireless solution. This User's Guide will describe the operation of your SKYWAY 7000 unit in detail.

### SYSTEM FEATURES

- Field proven OFDM modulation allowing near line-of-sight deployment and strong immunity to multi-path.
- Data rates from 6 Mbps to 108 Mbps.
- High power radio (up to 400mW) and improved radio sensitivity for best in class link ranges.
- Power over Ethernet (PoE) for simplified cable routing.
- Integrated antenna/radio simplifies installation and eliminates lossy RF coax runs.
- Frame aggregation for enhanced data throughput.
- Improved diagnostics and event log.
- Line speed QoS packet inspection prioritizes latency sensitive, real-time data.
- Line speed AES encryption for the ultimate in security and data protection.
- Spectrum Analyzer mode.
- Intuitive Web based user interface.

### PACKAGE CONTENTS

- SKYWAY 7000 Client Unit.
- 48VDC Power Supply.
- Power over Ethernet (PoE) injector.
- Two-axis mast mounting kit.
- Ethernet cable weatherproofing feedthrough.
- CD-ROM containing documentation and software utilities.
- Warranty and Compliance Card.

NOTE: CAT5 Ethernet cables are not included in the package. Please contact Solectek for information on available UV-protected Ethernet cables for outdoor use.

### Management Platform Requirements

- a) For GUI management: Pentium III (or equivalent) computer; Windows 2000 / XP (or equivalent); Internet Explorer v6.0
- b) For SNMP management: SNMP v1 or v2 compatible SNMP manager, running on appropriate PC platform.

## 2. Installation Outline

This section summarizes the steps needed to properly configure and install your Solectek 7000 multipoint Client Unit. As the details and guidelines for much of the radio installation process are well covered in many in-depth publications and training classes, only those steps that uniquely relate to the SkyWay 7000 product are covered in this User Guide.

### A. System Design

- RF Design and Site Survey
- IP Network Design

### B. Unit Preparation

- Unit connection (Section 3)
- Configuration (Section 4-7)
- Bench testing (Section 8)

### C. Site Preparation

- Selection of unit mounting location
- Cable routing
- Preparation of mast and other supporting structures

### D. Physical Installation

- Mounting of the outdoor equipment (Section 9)
- Reconfirmation of spectrum analysis (Section 10)
- Antenna alignment (Section 11)

### E. Verification

- Link status + metrics (Section 12)
- Ping connectivity
- Performance testing
- Reliability monitoring

### F. Optimization

- RF channel tuning
- Data rate tuning (see Product 'Range Guide')
- Frame Aggregation (feature details in Section 4)
- QoS (Section 13)

### G. Management + Maintenance

- Monitoring link quality and performance (Section 12)
- SNMP (Section 14)
- Login/Password (Section 15)
- Software upgrades (Section 16)
- Reboot (Section 17)

### H. Troubleshooting

- Event Log (Section 18)
- Diagnostics (Section 19)
- FAQ (see Appendix B and [www.solectek.com](http://www.solectek.com))

## 3. System Connection

### A. CONNECTING THE SKYWAY UNIT

Using the appropriate diagram below as a guide (direct to a PC or through a switch), cable your SkyWay test system. Connect your PC to the POE injector using (a) crossover Ethernet cable or (b) straight cable and a hub/switch.

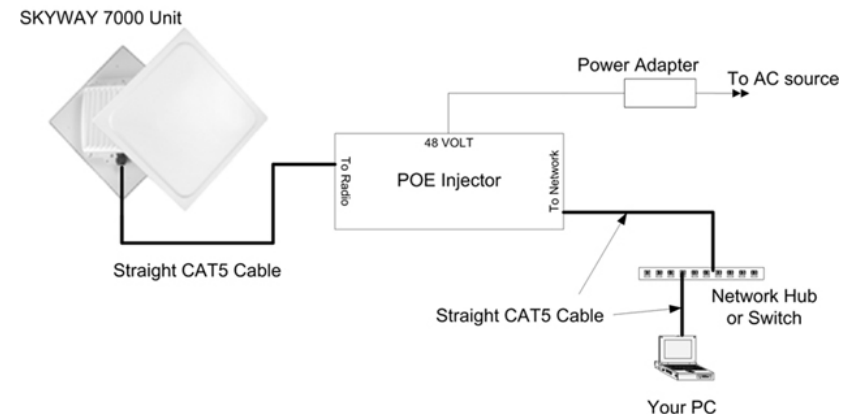
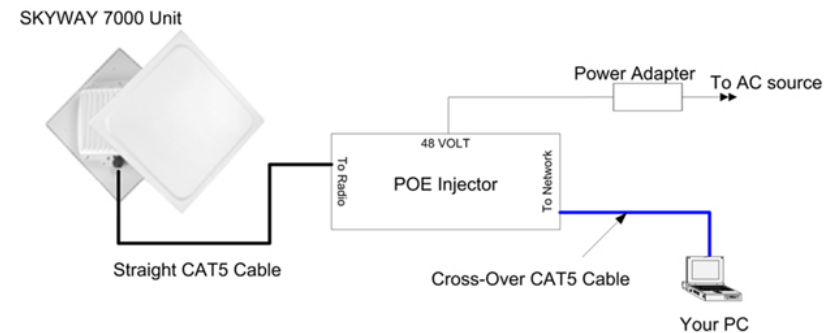

## B. CONFIGURE TCP/IP PROPERTIES OF TEST PC (WINDOWS)

Open *networking properties* in your Windows OS. Find the TCP/IP setup window of your wired Ethernet adapter. The details on how to set the IP address of your computer's Ethernet adapter may depend on Windows version used. Shown below is the Windows 2000 TCP/IP Properties window. Set the IP addresses to the following values.

Ethernet's IP Address: 192.168.0.100  
Subnet Mask: 255.255.255.0

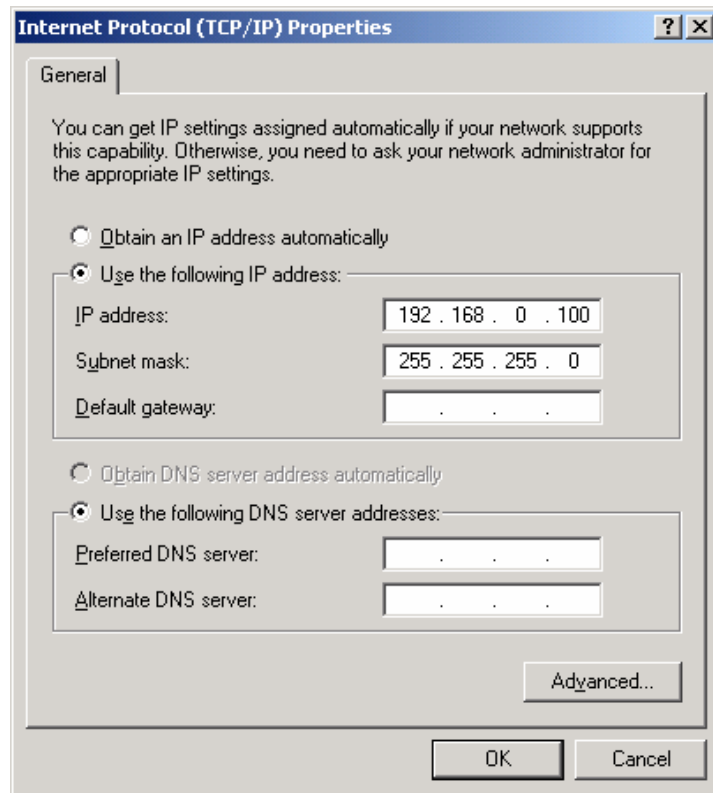

## C. LOG-IN TO YOUR SKYWAY

- Open a Web Browser on the Test PC
- At the URL line, type in the following: `http://192.168.0.2` to access the **Welcome** screen below.
- Click on the **login** menu option located in the navy-blue left menu bar. The following screen should appear:

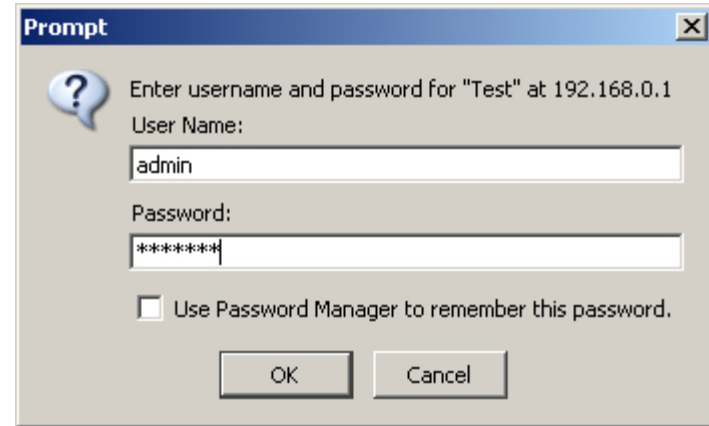

- The default username is **admin** and the default password is **default**. Once logged in, the password can be changed. Click OK and you will see the Main Status screen as shown:

## Main Status

### Unit

**System Name:**  
**Firmware Version:** 02.00.00  
**Serial Number:**  
**Up Time:** 00:11:59

**Network Mode:** Bridge  
**MAC Addr:** 00:C0:61:00:6F:02  
**IP Address:** 192.168.0.2  
**Subnet Mask:** 255.255.255.0  
**Default Gateway:** 0.0.0.0

### Ethernet Port

[details](#)

**MAC Addr:** 00:C0:61:00:00:03  
**State:** ●

### RF Port

[details](#)

**MAC Addr:** 00:C0:61:00:6F:02  
**Spectrum:** 20 MHz  
**Radio Frequency:** 5735 MHz  
**Data Rate:** 6 Mbps  
**State:** ●

## 4. Basic Configuration

### A. CHOOSING BRIDGING OR ROUTING

The choice between bridging and routing is a key decision that needs to be made regarding the use of the SkyWay 7000 radio within your network. Because bridging and routing often require different configuration settings, the GUI menus will change depending on the mode of operation. To help clarify these differences, this *user's guide will highlight routing only options in **BLUE and Italic***, to emphasize the distinctions.

The navigation toolbar (example shown below) is on the left side of every screen. Use this navigation toolbar to access different screens of the user interface.

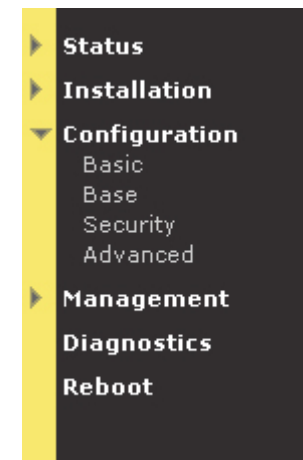

- Click the **Advanced** menu option under the **Configuration** category on the Navigator Toolbar to access the **System** screen as below:

## Advanced

---

### Mode of Operation

Mode:  Bridge  Router

Changing Unit's Mode will affect your Ethernet MAC Address!  
Clear your ARP Table Entry in order to connect to the Unit again!

---

### RF Output Power

Options:  Full  -6dB

---

### Throughput Optimization

Distance to Base (miles):

Frame Aggregation:  Enable  Disable

---

### Management Access

via VLAN:  Enable  Disable

VLAN ID (1-4095):

- Mode of Operation

The user first needs to determine whether the unit will operate in the **Bridge** or **Router** mode. The **Bridge** mode is the system default option. Be sure to reboot the unit if you change the mode of operation.

- RF Output Power

The **RF Output Power** should be normally kept at the **Full** value to maintain the maximum link margin. You may need to choose the **-6dB** value if the link distance is very short. The reduction of power can prevent receiver saturation.

**NOTE:** The 7100 short range client unit has a different menu for the RF Output Power: **High, Medium, and Low.**

- Throughput Optimization

**Distance to Base:** The system adjusts internal parameters according to the chosen link distance to maximize the data throughput.

Enter the link distance (in miles) to the peer unit, known or expected.

The system default is 10 miles. Be sure that the correct distance is selected for link distances over 10 miles.

Please note that the actual maximum link distance depends on the radio model deployed and link conditions. A SkyWay 7000 range guide is available on Solectek's web site, [www.solectek.com](http://www.solectek.com).

**Frame Aggregation:** Since the overhead associated with the encapsulation and RF transmission of frames is fixed per packet, the transmission of smaller frames is less efficient as the overhead takes on a larger percentage of total traffic.

The SkyWay 7000 unit performs frame packing, which aggregates small frames into a large one before transmission. This will maximize the overall throughput of your payload data.

The aggregation system is dynamic in the sense that packing size is also a factor of link activity and latency considerations.

The default state for frame aggregation is **Enabled**. You may want to **Disable** frame aggregation if your RF link has excessive errors (due to RF interference, for example). Small packets may have better probability of successful transmission and you may have an improved link performance.

- Management Access

**VLAN:** Your SkyWay 7000 series units will bridge/route VLAN frames transparently at all times, i.e. all frames tagged with VLAN ID's will be recognized and passed though the system. The unit will NOT tag or strip VLAN ID's. In this sense, the unit will be transparent to VLAN frames.

The VLAN feature option affects the accessibility of the SkyWay 7000 user interface by Management computers within a VLAN.

- o **Enable/Disable.** If access to the Web GUI will be from a PC within a VLAN, then this feature should be Enabled. If access is from a PC outside of a VLAN, then this feature should be disabled.
- o **VLAN ID:** The ID should be set to match the VLAN ID used on your management PC. This setting does not affect any other VLANs running on your network or the ability to pass VLAN traffic.

If you have made any changes, click the **Update** button. Then, navigate to the **Reboot** menu option and follow instructions to restart the unit.

## B. IP and Wireless Configuration

Click the **Configuration** -> **Basic** menu option on the Navigator Toolbar to access the following screen if in *Bridging* mode:

The screenshot shows the 'Basic Configuration' page in Bridging mode. It features a 'System Name' input field at the top. Below it are three sections: 'LAN', 'Wireless', and 'Default Gateway'. The 'LAN' section contains IP Address (192.168.0.2), Subnet Mask (255.255.255.0), and Default Gateway (0.0.0.0) fields. The 'Wireless' section includes a 'Radio Spectrum Bandwidth' dropdown set to '40 MHz', a red warning message, a 'Select' button, a 'Data Rate' dropdown set to '108 Mbps', and 'Update' and 'Reset' buttons at the bottom.

The **Basic Configuration** page is slightly different when in *Routing* mode:

The screenshot shows the 'Basic Configuration' page in Routing mode. It features a 'System Name' input field at the top. Below it are four sections: 'Ethernet Port', 'RF Port', 'Default Gateway', and 'Wireless'. The 'Ethernet Port' section contains IP Address (192.168.0.2) and Subnet Mask (255.255.255.0) fields. The 'RF Port' section contains IP Address (192.168.1.5) and Subnet Mask (255.255.255.0) fields. The 'Default Gateway' section contains an IP Address (0.0.0.0) field. The 'Wireless' section includes a 'Radio Spectrum Bandwidth' dropdown set to '40 MHz', a red warning message, a 'Select' button, a 'Data Rate' dropdown set to '108 Mbps', and 'Update' and 'Reset' buttons at the bottom.

- System Name

This is a description of the unit used to simplify the identification of a particular radio in the wireless network. This parameter is not related to the identification of the unit on your wired local area network. For security purposes, the System Name is not broadcast across the RF link.

- LAN IP Configuration (Bridging)

If the unit is in Bridging Mode, then the following parameters need to be configured:

**IP Address:** This is the IP address of the unit.

**Subnet Mask:** This is the subnet mask of the unit.

**Default Gateway:** the default gateway of the unit.

*If the unit is in Routing Mode, then both Ethernet and RF ports are assigned IP addresses as follows:*

- *Ethernet Port (Routing)*

*IP Address:* Enter the IP address of the Ethernet port.

*Subnet Mask:* Enter the correct Subnet Mask of the Ethernet port

- *RF Port (Routing)*

*IP Address:* Enter the IP address of the RF port.

*Subnet Mask:* Enter the correct Subnet Mask of the RF port

- *Default Gateway (Routing)*

*IP Address:* Enter the correct gateway IP address

- Wireless properties

**Radio Spectrum Bandwidth:** There are two choices are available – 20 MHz and 40 MHz.

If a radio is likely to be installed in an area with other 5.8 GHz radios nearby, it is best to use the 20 MHz bandwidth setting as this allows for more non-overlapping channels. This is also the case if multiple radios are to be co-located on a single tower or rooftop.

If maximizing throughput and distance is of primary importance, then it may be best to use a 40 MHz bandwidth. At any given datarate (e.g. – 36 Mbps), the 40 MHz setting will attain a longer link distance as compared to the 20 MHz setting. The 40 MHz setting also allows for higher data rate settings not available on the 20 MHz setting.

After changing the Radio Spectrum Bandwidth value, be sure to click the **Select** button below.

The following is a table of available radio frequencies and data rates for each option. (Note that the allowable frequencies may differ from the table below depending on the country of operation)

20MHz Channel	
Frequency (MHz)	5735, 5755, 5775, 5795, 5815, 5835
Data Rate (Mbps)	54, 36, 18, 9, 6

40MHz Channel	
Frequency (MHz)	5745, 5785, 5825
Data Rate (Mbps)	108, 72, 36, 18, 12

**Radio Frequency (MHz):** the center frequency of the selected channel. Note that the frequency channel you select for the base station is that for the entire multipoint network. The client unit will operate at this frequency channel.

**Data Rate:** air transmission data rates. Note that different data rates are available for 20 MHz and 40 MHz modes, as detailed in the table above.

All radios on a given wireless network must use the same Bandwidth, and Frequency. The Data Rate setting refers to a Radio's *transmit* rate. It is not necessary to have symmetrical Data Rates across a link.

After changes are complete, click on the **Update** button. If a mistake is made, you can restore the previous setting by clicking the **Reset** button. To make changes effective, reboot the unit by clicking on **Reboot** from the Navigation Toolbar.

**NOTE:** Clients units do not have choices of radio frequency channels. Clients units scan the available channels and lock on the frequency channel of the base station.

## 5. Additional Routing Configuration

There are two mechanisms to build up the system's route table: Static routing or RIP. The choice depends on your overall network design topology and preferences.

### A. Static Routing

To activate Static Routing, navigate to the **Configuration -> Static Routes** menu option in the navigation toolbar to view the following screen:

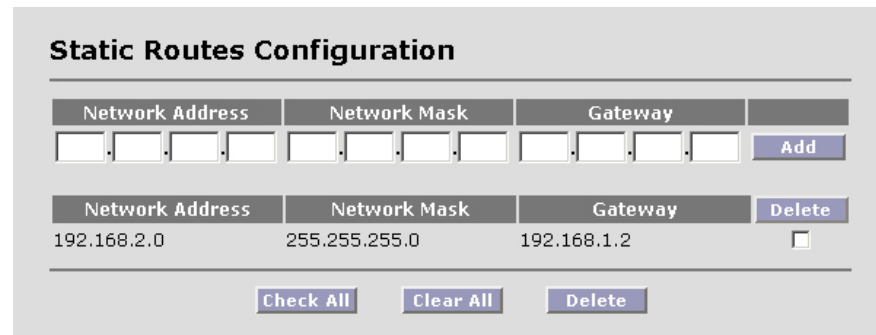

The Static Routes Configuration screen features a table with columns for Network Address, Network Mask, and Gateway. The first row contains input fields for these values and an 'Add' button. The second row shows a populated entry: Network Address 192.168.2.0, Network Mask 255.255.255.0, Gateway 192.168.1.2, and a 'Delete' checkbox. Below the table are three buttons: 'Check All', 'Clear All', and 'Delete'.

For each static route, you need to add the following information

**Network Address** – Enter the network address of the static route.

**Network Mask** – Enter the network mask of the static route.

**Gateway** – Enter the gateway of the static route.

Once entered, click the **Add** button to include the newly typed static route to your static route list (as shown on the bottom of the screen).

You can delete a static route by checking the box to the right of the static route and clicking the **Delete** button. Additional grouping functions are available as follows:

**Check All:** You can check all boxes by clicking this button. This is usually used when you want to delete all static routes. Be careful in using this button, as it could erase all of your routing information.

**Clear All:** Clicking this button will uncheck all boxes.

**Delete** - Both **Delete** buttons on the screen achieve the same result: deleting all route entries with checked boxes.

You can find the current routing status by navigating to **Status -> Routing** menu option:

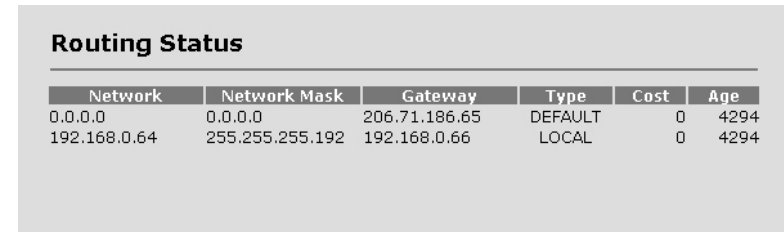

The Routing Status screen displays a table with the following data:

Network	Network Mask	Gateway	Type	Cost	Age
0.0.0.0	0.0.0.0	206.71.186.65	DEFAULT	0	4294
192.168.0.64	255.255.255.192	192.168.0.66	LOCAL	0	4294

### B. RIP (Router Information Protocol)

Navigate to the **Configuration -> RIP** menu option to activate the RIP based routing

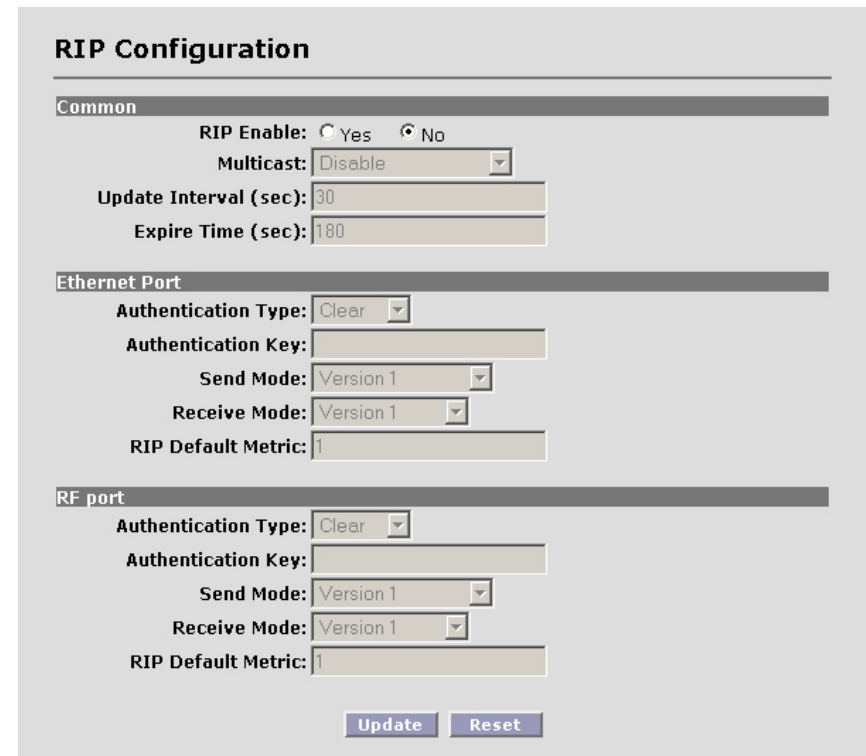

The RIP Configuration screen is divided into sections: Common, Ethernet Port, and RF port. The Common section includes 'RIP Enable' (radio buttons for Yes and No), 'Multicast' (dropdown menu), 'Update Interval (sec): 30', and 'Expire Time (sec): 180'. The Ethernet Port section includes 'Authentication Type' (Clear dropdown), 'Authentication Key' (text field), 'Send Mode' (Version 1 dropdown), 'Receive Mode' (Version 1 dropdown), and 'RIP Default Metric: 1'. The RF port section includes identical fields for Authentication Type, Authentication Key, Send Mode, Receive Mode, and RIP Default Metric. At the bottom are 'Update' and 'Reset' buttons.

The following describes the menu items in the RIP Configuration screen:

- Multicast

Though typically not implemented across the public Internet, Multicast for IP support is possible across SkyWay 7000 when RIP v2 is enabled. SkyWay 7000 can be configured to use the multicast address 224.0.0.9 to proliferate route updates, thus reducing broadcasts of route updates.

- Update Interval

By default, every 30 seconds the SkyWay 7000 router will advertise its routes to other RIP v2 devices. This value can be changed, but it must remain a multiple of the value for EXPIRE TIME.

- Expire Time

This field defines how long the route table entries remain in the SkyWay 7000 route table. The default is 180 seconds.

The following describes port configuration related to RIP. Please note that default configuration fields are identical for the Ethernet and RF ports, but can be configured differently.

- Authentication Type

**Clear:** RIP will announce updates and listen for all RIP updates on the specified interface.

**Simple:** RIP expects updates to include an authentication key. The key will be transmitted in clear text.

**MD5:** per RFC 1321, MD5 Message Digest Algorithm and RFC 2082 RIP-2 MD5 Authentication. Route update authentication keys are entered by user as plain text. Keys are taken as input by the MD5 algorithm and output as a 128-bit "fingerprint" or "message digest"

- Authentication Key

Enter the authentication key for the given port.

- Send Mode

**Version 1:** sends only RIP v1 updates.

**Ver1 Compatible:** sends v2 updates but will listen for v1 (if MULTICAST is enabled only version 2 is used).

**Version 2:** sends RIP v2 updates only, no backwards compatibility.

**None:** will still listen for and process updates but will not send any updates on this interface

- Receive Mode

**Version 1:** listens for and will update self with v1 updates only.

**Version 2:** listens for and will update self with v2 updates only.

**VERSION 1 & 2:** listens for and will update self with v1 & v2 updates

- RIP Default Metric

**1:** at the default, this SkyWay interface believes it is one hop away from the nearest gateway interface. Increasing this value by single digit orders this routing interface to let all other RIP-enabled routers believe that it is a secondary or higher cost path (typically used for redundancy).

After changes are complete, click on the **Update** button. If a mistake is made, you can restore the previous setting by clicking the **Reset** button. To make changes effective, reboot the unit by clicking on **Reboot** from the Navigation Toolbar.

## 6. Encryption

To manage a unit's security settings, click on **Configuration** -> **Security** from the Navigation Toolbar to display the following screen.

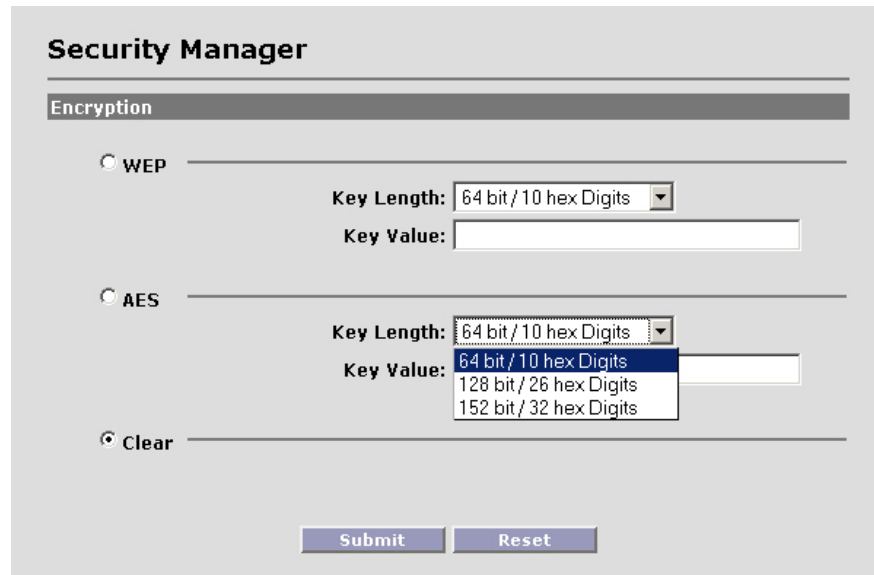

The screenshot shows the 'Security Manager' interface with the 'Encryption' tab selected. There are three radio button options: 'WEP', 'AES', and 'Clear'. The 'Clear' option is currently selected. For both 'WEP' and 'AES', there is a 'Key Length' dropdown menu set to '64 bit / 10 hex Digits' and a 'Key Value' text input field. The 'Key Value' field for 'AES' has a dropdown menu open showing three options: '64 bit / 10 hex Digits', '128 bit / 26 hex Digits', and '152 bit / 32 hex Digits'. At the bottom of the screen are 'Submit' and 'Reset' buttons.

Three data encryption options are available: none, AES and WEP. Within both AES and WEP, there are several key length choices.

If encryption is enabled, the key value must be the same for all units within a wireless network. Key values are entered in hexadecimal format – each digit can be a number from 0 - 9 or a letter from a - f.

After changes are complete, click on the **Submit** button. If a mistake is made, you can restore the previous setting by clicking the **Reset** button. To make changes effective, reboot the unit by clicking on **Reboot** from the Navigation Toolbar.

## 7. Access Control

For security purposes, each base and client unit must be programmed with the MAC address of its remote unit.

To access the relevant web screen click on the **Configuration** -> **Base** menu option on the Navigation Toolbar.

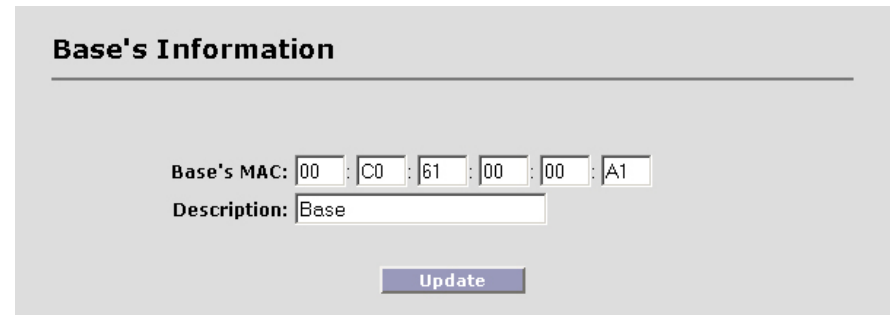

The screenshot shows the 'Base's Information' screen. It features a 'Base's MAC' field with a dropdown menu showing the address '00 : C0 : 61 : 00 : 00 : A1'. Below it is a 'Description' text input field containing the word 'Base'. At the bottom right is an 'Update' button.

**Base's MAC:** This is the hardware RF MAC address of the Base Station. This MAC address can be found on the base's user interface or on the back label. The correct address must be used to establish an RF link with the base.

**Description:** Type in any description that will easily identify the peer with the above MAC address. This is an optional field for your convenience only and has no effect on the operation of the unit.

The base station also needs to have this client unit's RF MAC address in its access list for RF link to be established.

## 8. Benchtesting

Before mounting units into their final location, it is recommended to benchtest the system to ensure settings are correct. The following benchtest steps are suggested:

**Setup.** The most straightforward approach to benchtesting is to establish a Point-to-Point link or a Base Station linked with a single Client. Each radio should be connected and configured per Sections 3 - 5, with a laptop or PC connected to each radio directly (or through a hub). Be sure that Access Control MAC addresses are correct and that units share the same frequency, bandwidth, data rate and encryption settings.

**Positioning.** It is important to remember that the Skyway 7000 radio and antenna system generate and transmit a great deal of RF power. During benchtesting in an average sized room, the antennas should not be pointed directly at each other. Instead, rotate the unit 90 degrees away from each other. Fine tune the antenna position so that the Signal Level field in the Detailed Status Screen is at mid-span.

**Testing.** If the system has been properly configured, the radios will begin communicating immediately. The following steps are recommended to verify operation:

- Link State. On the Main Status screen, verify that the RF Link State is Green (connected).
- Local ping. From each laptop/PC be sure a ping to the local radio is successful.
- Link ping. Now ping from one laptop/PC to the other laptop/PC. This will verify the end-to-end link.
- Throughput test. Using Qcheck, or equivalent throughput measurement utility, verify system performance.

### Notes:

(a) Keep in mind that the Skyway7000 data rates can easily stress the performance of a poorly performing TCP/IP/Ethernet stack on a laptop or PC. To ensure that the test equipment is not the bottleneck, testing with a direct connection between laptops/PCs is strongly recommended.

(b) Using a single FTP session on a typical Windows/Intel machine is not adequate to accurately measure throughput.

## 9. Physical Installation

### A. INTRODUCTION

Your SkyWay 7000 radio is designed to be mast mounted on a rooftop or radio tower. After determining the best location for your radio, installation can begin. Please refer to Solectek's *RF Site Design Guide* on Solectek's website ([www.solectek.com](http://www.solectek.com)) for more information about choosing an ideal radio location.

To mount a SkyWay 7000 radio, both the mast mounting kit and Ethernet cable feedthrough need to be correctly assembled. The recommended approach consists of 3 steps, detailed in the following sections:

1. L-bracket installation
2. Ethernet cable / feedthrough assembly
3. Mast mounting

With the exception of the CAT5 cable, all parts and hardware described in the following sections are included with your SkyWay 7000 radio.

### B. L-BRACKET INSTALLATION

The L-bracket is fastened to the radio using four 1/4" x 1/2" hex flange bolts as shown in the following diagram. **The mast is shown here only to illustrate the orientation of the bracket against the enclosure.**

Be sure to align the L-bracket so that the orientation and polarization of the antenna is correct when it is mounted on a mast.

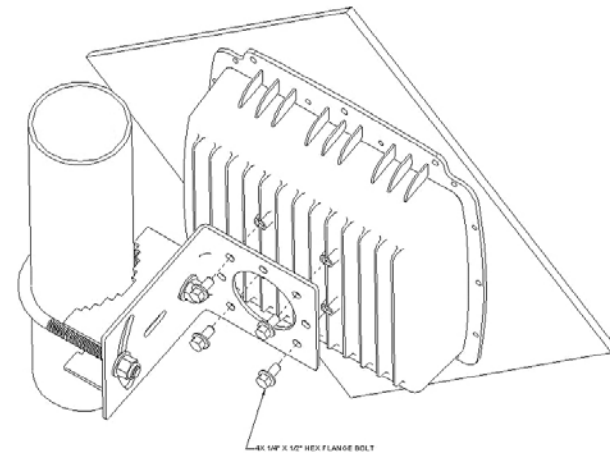

### C. ETHERNET CABLE / FEEDTHROUGH ASSEMBLY

Only a single Ethernet cable is needed to connect the Skyway radio to the indoor PoE Injector. Since the cable is exposed to the outdoor elements (heat, moisture, and UV light), only outdoor rated, shielded Cat5 Ethernet cable should be used. To ensure all-weather operation, the weatherproofing cable feedthrough (also known as grommet or gland) must be properly assembled onto the Ethernet cable and radio.

The following diagram depicts each of the feed-through parts:

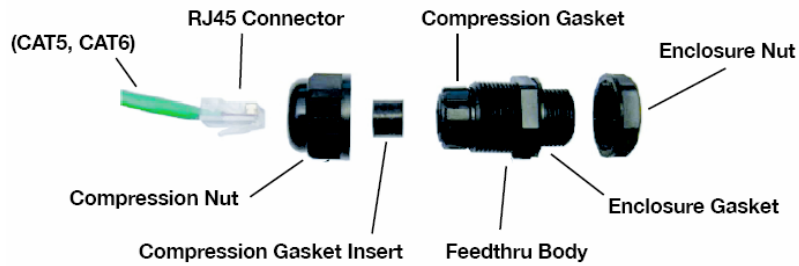

The following steps must be followed to make sure that the feedthrough is assembled correctly:



1. Remove the **Compression Nut** and slip it over the Ethernet CAT5 cable as shown above.
2. Slip the **Compression Gasket Insert** over the Ethernet CAT5 cable
3. Feed the Ethernet CAT5 Cable through the **Feedthrough Body** (pre-installed on the enclosure at the factory) and insert the RJ-45 connector to the female connector inside the enclosure.



4. Slide the **Compression Gasket Insert** into the **Compression Gasket**, as shown above. Make sure to slide the **Insert** fully, such that the two parts are evenly aligned.



5. Install the **Compression Nut** and hand tighten until the cable resists slipping when gently pushed or pulled. Lightly wrench-tighten, being careful not to overtorque the **Compression Nut**.

The unit with properly installed feedthrough appear as follows:



Note: the total combined length of the Ethernet cables between the radio and your network access device (hub/switch/PC) must not exceed 300 feet.

Note: In order to maintain FCC compliance, the use of shielded CAT5 cable is required.

## D. MAST MOUNTING

The final installation step involves mounting your SkyWay 7000 radio to an outdoor mast.

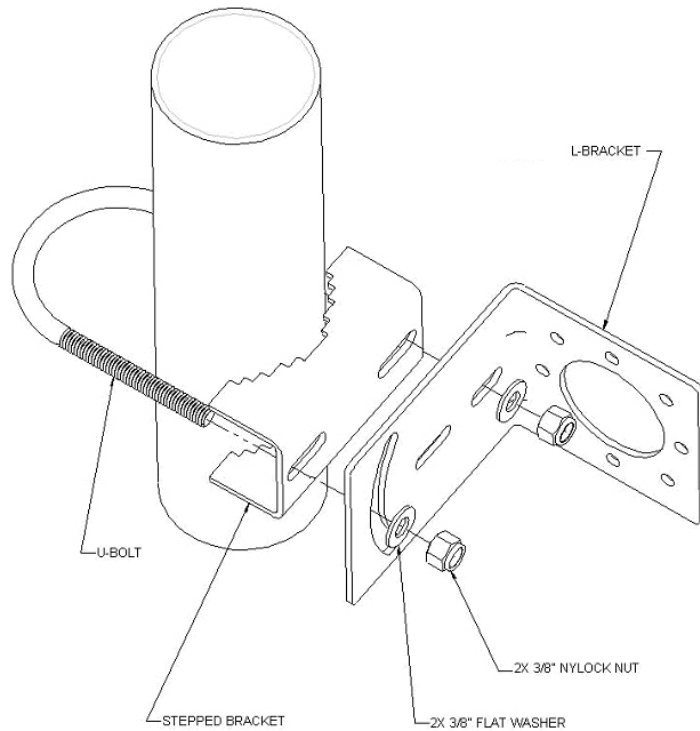

1. Slide the U-bolt around the mast, through the stepped bracket, and then through the L-bracket.
2. Insert 3/8" flat washers on to the ends of the U-bolt.
3. Thread two 3/8" nylock nuts on to U-bolt ends.
4. For azimuth antenna adjustment, loosen the inner U-bolt nut and rotate radio around mast.
5. For elevation adjustments, loosen the outer U-bolt nut and adjust radio so that the U-bolt leg slides along L-bracket slot.
6. Wrench tighten both nuts following antenna alignment.

## 10. Spectrum Analysis

Your SkyWay unit comes with embedded spectrum analysis tool to facilitate your site survey (NOTE: This feature is available on software version 2.0 or higher). Spectrum analysis provides valuable information about the RF congestion in the local area and allows the selection of the ideal channel.

Prior to enabling a spectrum analysis, ensure that the units are mounted at the desired location and align the antenna in the general direction of the peer radio before beginning the analysis.

**Note:** Do not turn on the remote unit during the spectrum analysis, as the presence of the remote unit will severely distort the sweep data.

Navigate to the **Installation -> Spectrum Analysis** menu to access the Spectrum Analysis screen:

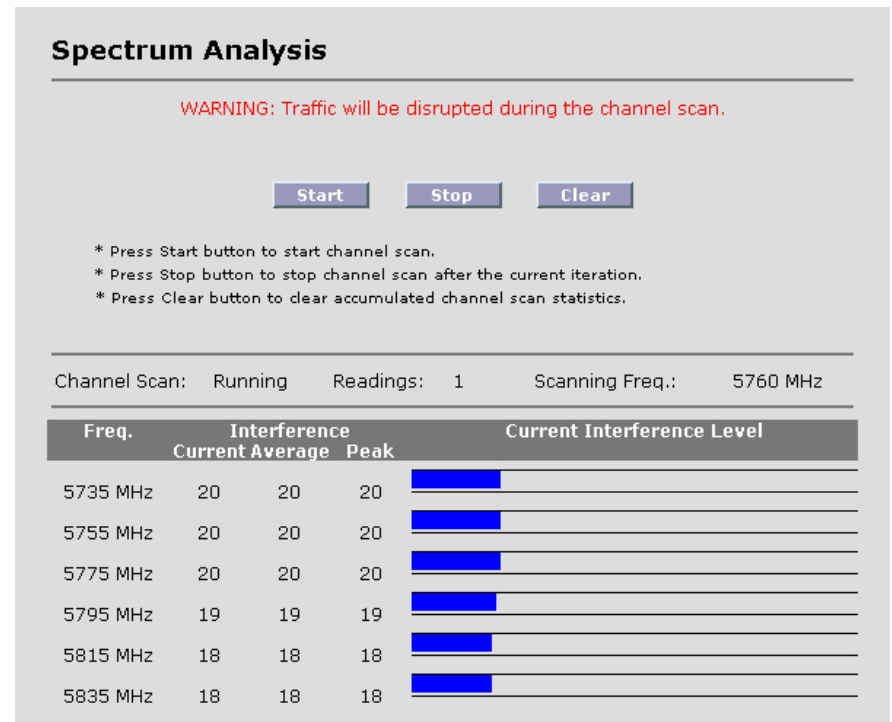

To start the spectrum analysis, click **Start** button. The unit will scan through the available channels and display the results on the bottom half of the screen. Numerical results will indicate the interference levels based on received signals

from each channel. The blue graph can be used for easy comparison among the channels.

The numbers shown to the right of each frequency band are on a relative scale calibrated in dB and represent the noise power in each band.

Depending on the anticipated nature and severity of local interference, scan time can vary from a few minutes to a few hours. In extreme cases where interference may be tied to time of day, a 24 hour sweep may be warranted. In longer sweeps, refer to average and peak noise figures for the most appropriate measure of interference.

Once you are finished with the spectrum analysis, click the **Stop** button, which will stop the channel sweep and return the unit to normal operating mode.

Clicking the **Clear** button will zero out all accumulated channel sweep statistics.

## 11. Antenna Alignment

A separate antenna alignment screen facilitates the physical antenna alignment procedure. Navigate to **Installation -> Alignment** to see the following screen:

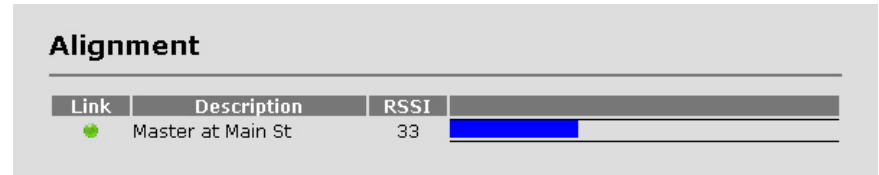

**Link:** The circle will turn from red to green when the wireless link is established as a result of antenna alignment.

**Description:** This is the system name given to the unit in the Configuration screen.

**RSSI:** A relative measure of power received by the radio currently logged into. This is the measure of the remote unit's transmit power as received by your unit.

At 36 Mbps, the RSSI should be at least 20. For higher data rates, the RSSI must be higher to support reliable operation. At lower data rates, the RSSI can fall below 20 and still maintain a reliable link. A sample of minimum RSSI levels required is provided below:

Minimum RSSI at different data rates	
36 Mbps	20
72 Mbps	25
108 Mbps	32

## 12. Verifying Operation

The basic status of the unit can be viewed in the Main Status screen. Shown here is the Main Status screen in bridging mode:

**Main Status**

---

**Unit**

System Name:  
 Firmware Version: 02.00.00  
 Serial Number:  
 Up Time: 00:11:59

Network Mode: Bridge  
 MAC Addr: 00:C0:61:00:6F:02  
 IP Address: 192.168.0.2  
 Subnet Mask: 255.255.255.0  
 Default Gateway: 0.0.0.0

---

**Ethernet Port** [details](#)

MAC Addr: 00:C0:61:00:00:03  
 State: ●

---

**RF Port** [details](#)

MAC Addr: 00:C0:61:00:6F:02  
 Spectrum: 20 MHz  
 Radio Frequency: 5735 MHz  
 Data Rate: 6 Mbps  
 State: ●

This screen updates periodically and thus displays current field values. Navigate to the **Configuration** screen if setting changes are necessary.

Three noteworthy items:

- **Up Time:** This is the elapsed time that the unit has been running since the last reboot or power cycle.
- **MAC Address:** this is the MAC address of the unit.
- **RF Port Link State:** The link state has two values.

Green – An RF link has been established  
 Red – an RF link is NOT established.

Each of the ports also has its own, detailed status screen. For the Ethernet Port status, click on the **details** button located on the far right side. The screen below is typical:

**Ethernet Port**

---

**Main** [Clear Statistics](#)

MAC Address: 00:C0:61:00:72:01  
 MTU Size: 1500  
 State: ●

---

Local Statistics	Receive	Transmit
Total Frames:	808	1089
Total Octets:	206229	611610
Bandwidth Usage [kbps]:	3	11
Unicast Frames:	808	937
Non Unicast Frames:	0	152
Errors:	0	0

---

**Detailed Receive Errors**

Discarded Frames: 0  
 Unknown Protocols: 0

---

**Detailed Transmit Errors**

Collisions: 0

[Back](#)

**MTU Size:** This is the maximum datagram size that the system is able to transmit. Note that this refers to Ethernet payload not total Ethernet frame size.

**State:** There are two states, Green – Port Up. Red – Port Down.

**Total Frames:** total number of frames received and transmitted by the Ethernet port.

**Total Octets:** total number of octets (bytes) received and transmitted by the Ethernet port.

**Bandwidth Usage [kbps]:** average utilization of the Ethernet port over the last 5 seconds.

**Discarded Frames:** PHY layer errors

**Unknown Protocols:** MAC layer errors

**Collisions:** MAC layer errors, representing dropped packets.

The RF Port (click on the **details** button on the Main Status screen next to each client's description) also has its own detailed screen:

**RF Port**

State [Clear Statistics](#)

**Local RF MAC:** 00:C0:61:00:00:02  
**Local Descr:**  
**Base RF MAC:** 00:C0:61:00:00:04  
**Base Descr:** 1st St

**Link State:** ●  
**Link Distance:** 12 miles  
**Encryption:** None

**Spectrum:** 20 MHz  
**Frequency:** 5120 MHz  
**Data Rate:** 6 Mbps  
**Local RSSI:** 45  
**Signal Level:**

Local Statistics	Receive	Transmit
<b>Valid Data:</b>	147	114
<b>Valid Mgmt:</b>	2	2
<b>Errors:</b>	0	0

Local Rx Errors	Frames	Error Rate(%)
<b>CRC Errors:</b>	0	0

Local Tx Errors	Frames	Error Rate(%)
<b>Discarded Frames:</b>	0	0

[Back](#)

Fields for this screen include:

- **Local RF MAC:** The RF port MAC address of the unit.
- **Local Descr:** The description assigned to the unit (client unit) in its Configuration screen.
- **Base RF MAC:** Indicates the RF port MAC address of the client unit. Recall that this address must be valid to establish an RF link.
- **Base Descr:** The description assigned to the client unit in the **Base's Information** screen.
- **Link State:** Green if a link is established and Red if not.

- **Local RSSI:** A relative measure of power received by the radio currently logged into. This is the measure of the remote unit's transmit power as received by your unit.

At 36 Mbps, the RSSI should be at least 20. For higher data rates, the RSSI must be higher to support reliable operation. At lower data rates, the RSSI can fall below 20 and still maintain a reliable link. A sample of minimum RSSI levels needed is provided below:

Minimum RSSI at different data rates	
36 Mbps	20
72 Mbps	25
108 Mbps	32

- **Signal Level:** A graphical representation of RSSI.

#### Local Statistics

- **Valid Data:** Total number of data frames received and sent by the unit.
- **Valid mgmt:** Total number of management frames received and sent by the unit
- **Errors:** total number of error frames recorded by the unit.

#### Local Rx Statistics

- **CRC Errors:** A wireless PHY layer statistic - specifies the number of frames rejected at the PHY layer of the radio receive chain.

#### Local Tx Statistics

- **Discarded Frames:** A wireless MAC layer statistic - specifies the number of frames for which the transmitting radio did not receive acknowledgment from the receiving radio. There are many possible reasons including an RF path problem, interference, defective receiver, etc.

The transmitting radio will try twice to send a frame. If both attempts result in failure, the radio will "discard" the frame and rely on higher layer protocols to request a retry.

## 13. Quality of Service (QoS)





For the transport of real-time data, such as VoIP or streaming video, the SkyWay 7000 contains a QoS system providing end-to-end prioritization of pre-tagged Ethernet and IP frames.

The QoS system relies upon the originating network device/appliance to tag frames using one of the following standards:

- 802.1p VLAN tag
- IP ToS field
- IP Diffserv field

As a frame enters the SkyWay 7000, a line speed tag inspection is performed and frames are prioritized as follows:

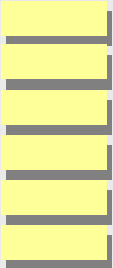
- A priority queuing method assigns tagged frames to one of the 4 priority queues, allowing higher priority data to then be pushed onto the RF stack ahead of lower priority frames. Tagged frames are assigned to queues based on the following tag matrix-

	Voice	Video	Normal	Background
				
<b>Tag Method</b>				
802.1p	0x6 0x7	0x3 0x4 0x5	0x0	0x1 0x2
ToS/Diffserv	0x30 0xe0	0x28 0x88 0xa0	Default	0x08 0x20

- Once on the RF stack, the RF MAC gives prioritized frames early access to the 'air' resulting in the frames being delivered sooner to the receiving radio.

#### Notes:

- The QoS system does not add or alter priority tags
- QoS is always 'enabled.'
- For best results, all network devices (switches, routers, gateways) between source and destination devices should be QoS aware.

## 14. SNMP

The SkyWay 7000 provides support for SNMP v1 and v2. To configure a unit's SNMP settings, click on **Management** -> **SNMP** from the Navigation Toolbar to display the following screen:

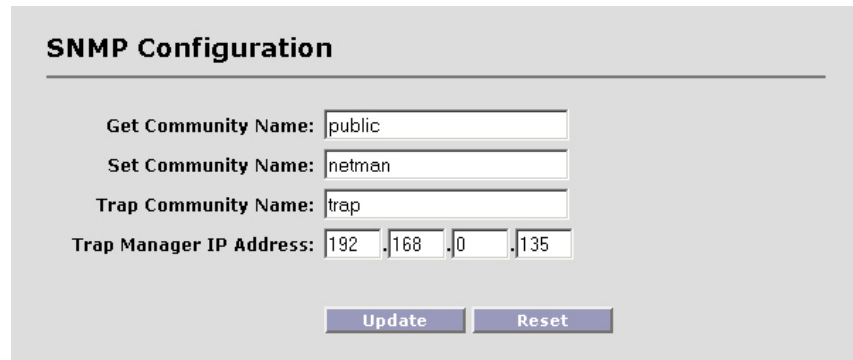

The screenshot shows the 'SNMP Configuration' web interface. It features a title bar 'SNMP Configuration' with a horizontal line below it. There are four input fields: 'Get Community Name' with the value 'public', 'Set Community Name' with 'netman', 'Trap Community Name' with 'trap', and 'Trap Manager IP Address' with the value '192.168.0.135'. At the bottom, there are two buttons: 'Update' and 'Reset'.

**Community Names** and **Trap Manager IP Address** fields should be entered based on the configuration of your SNMP Manager software.

Click on **Update** to activate changes.

Please refer to the User Manual of your SNMP Manager software for detailed information on establishing and managing units via SNMP.

A Solectek custom MIB is available via Solectek's web site. For further questions, please contact technical support.

## 15. Changing Your Login

To change the unit's password, click on **Management** -> **Password** from the Navigation Toolbar to display the following screen.

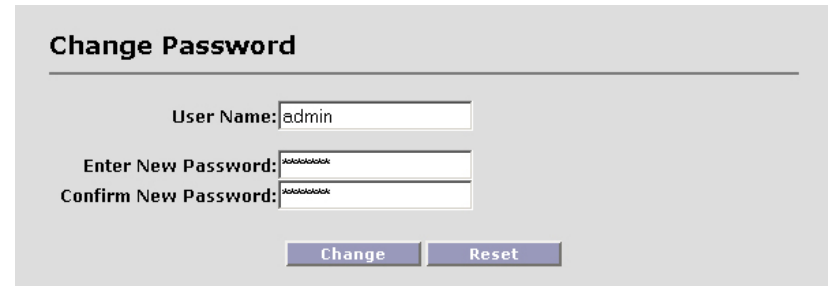

The screenshot shows the 'Change Password' web interface. It has a title bar 'Change Password' with a horizontal line below it. There are three input fields: 'User Name' with the value 'admin', 'Enter New Password' with masked characters, and 'Confirm New Password' with masked characters. At the bottom, there are two buttons: 'Change' and 'Reset'.

- **User Name:** User selected login name.
- **Enter New Password:** Enter the new password.
- **Confirm Password:** Re-enter the new password for confirmation.

Click the **Change** button to activate your new password. Click **Reset** to start over.

### Notes:

(a) Keep in mind that all three fields are case sensitive and no spaces are allowed.

(b) Please keep this password safe in your records. For your convenience you can write down the password in Appendix C.

## 16. Upgrading the Software

There may be newer software releases from Solectek periodically. The latest version will be posted on Solectek's website.

**NOTE:** You need to install an FTP server program on your computer to complete the following upgrade procedure. You can use an FTP program of your choice although Solectek has included FileZilla, an FTP server program, on the installation CD. For details on the configuration of this application, please refer to the product CD.

- Click on **Management** -> **Upgrade** to see the following screen:

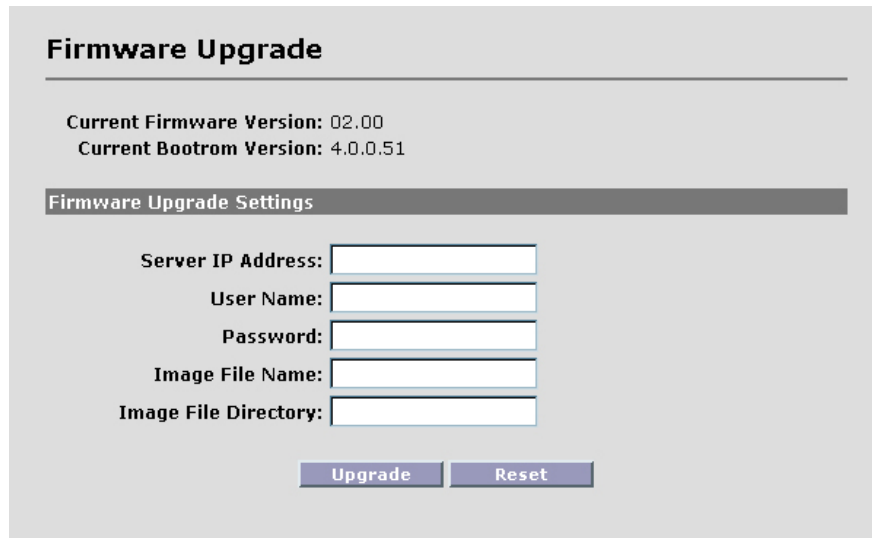

The screenshot shows a web interface titled "Firmware Upgrade". At the top, it displays "Current Firmware Version: 02.00" and "Current Bootrom Version: 4.0.0.51". Below this is a section titled "Firmware Upgrade Settings" which contains five input fields: "Server IP Address:", "User Name:", "Password:", "Image File Name:", and "Image File Directory:". At the bottom of the settings section are two buttons: "Upgrade" and "Reset".

**NOTE:** On certain upgrades, you may need to upgrade the Bootrom image in addition to the Firmware. Please consult the release notes of each firmware release for details.

Verify that the version available from Solectek is newer than the one currently installed on your SkyWay 7000.

To upgrade your system, first copy the latest SW file(s) from the Solectek website to a local PC. For convenience, you may prefer to use the same computer that you use to access the SkyWay 7000 user interface.

Next, complete the following fields:

- **Server IP Address:** The address of the computer that stores the upgrade software file.
- **User Name:** User name used to login onto the upgrade FTP server. For convenience, you may want to use **anonymous** login.
- **User Password:** Password used to login onto the upgrade FTP server.
- **Image File Name:** The name of the binary file to be loaded onto your SKYWAY 7000 unit. This file should have an \*.img extension and the full filename, including extension, should be entered into this field.
- **Image File Directory:** Directory path to find the software upgrade file on the FTP server.

NOTE: This path name is relative to the root path of the FTP server.

After all information has been entered correctly, click on the **Upgrade** button. The upgrade should take less than a minute, and the unit will automatically reboot once the upgrade is complete.

**REMINDER:** Do not power down or unplug the unit during the upgrade process. The updated firmware may become corrupted and the unit may not operate correctly.

## 17. System Reboot

To reboot the system from the Web Interface:

- Click on the **Reboot** menu option on the Navigation Toolbar. The following screen will appear:

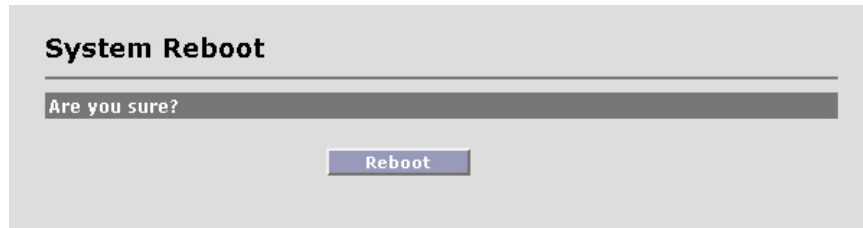

Click on the **Reboot** button to reset/reboot. The reboot process will take approximately 30 seconds. Once the rebooting is done, you can use the **Click Here** button below to access the user interface again.

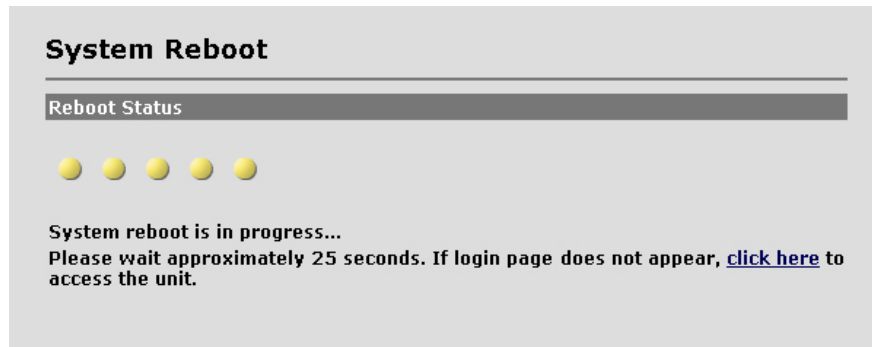

## 18. Event Log

The Event Log displays all major events that may be noteworthy for the system administrator for both monitoring and troubleshooting purposes.

The event log appears as follows:

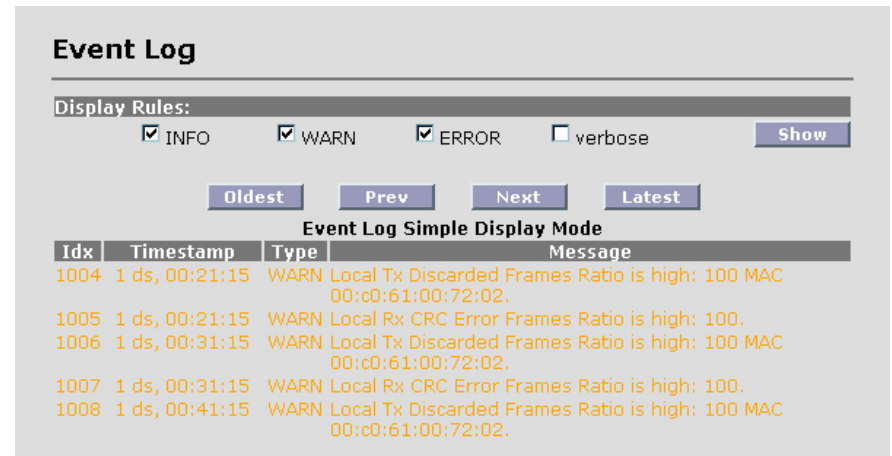

There are three categories of events:

**INFO:** This is informational in monitoring the operation of the unit. The Info line is part of the normal operation.

**WARN:** This may indicate something wrong with the unit or operation. For example, downing of the RF port may be due to malfunction or the user intervention (power off).

**ERROR:** This is indicative of abnormal operating conditions. For example, an error line may be caused by the user typing in unacceptable values in the user interface.

For easy viewing of specific information that you are looking for, each of the category (info, warn, and error) can be turned off to give you a more compact screen.

**Verbose:** This option adds further detail to each log event and is typically useful only when working with Solectek technical support. Under normal circumstances, it is recommended that the **Verbose** option be disabled.

## 19. Diagnostics

For diagnostics, navigate to **Diagnostics** menu to view the following:

**Diagnostics**

---

**System Time**

Cumulative On Time: 1 ds, 02:32  
Up Time: 0 d, 02:32:42

**Ping**

Destination IP Addr:

Packet Size (16-4008):

Packet Count:

**Ping is stopped**

```
PING 192.168.0.1: 56 data bytes
64 bytes from 192.168.0.1: icmp_seq=0. time=0. ms
64 bytes from 192.168.0.1: icmp_seq=1. time=0. ms
64 bytes from 192.168.0.1: icmp_seq=2. time=0. ms
----192.168.0.1 PING Statistics----
3 packets transmitted, 3 packets received, 0% packet loss
round-trip (ms) min/avg/max = 0/0/0
```

The ping diagnostics tool on the unit can be used to isolate the troubleshooting event to the wireless link only, not involving other network elements such as switches and host computers. You can ping the remote unit from the unit you are accessing via the user interface.

**Destination Addr:** The IP address of the device to be pinged.

**Packet Size:** The size of the ping packets to be sent (in bytes).

**Packet Count:** The number of packets to be sent to the destination IP address.

Click on the **Start** button to initiate the ping session. Click **Stop** to terminate it.

## Appendix A

### Factory Default Values

The following table details the factory default values. These are the values that will be set initially at the factory.

WIRELESS	
Radio Spectrum bandwidth	20 MHz
Channel	5795 MHz
Transmission Rate	36 Mbps

LAN	
IP Address	192.168.0.1 for Skyway 7600 or 7800 Base Stations
	192.168.0.2 for Skyway 7100, 7300 or 7500 Clients
	192.168.0.1 / .2 for Skyway 7101, 7301 or 7501 point to point pairs
Subnet Mask	255.255.255.0
Login Name / Password	admin / default

## Appendix B

### Troubleshooting Guide

#### 1. "I can't get a wireless connection between units"

- Verify that each radio has the correct RF MAC address programmed into its link configuration.
- Verify that both radios are operating on the same Radio Spectrum Bandwidth and Frequency.
- If encryption is enabled, verify that the key information been entered correctly.
- Make sure that the distance between the two radios is within the specified system range. A quick check of the signal strength and quality indicators can help assess a marginal RF link. Poor indicator response may be due to the following reasons:
  - Your link distance has exceeded the unit's capability: Review your link budget to make sure that the system is able to handle the distance. Use GPS devices to accurately determine the link distance first. If you are unsure about the link budget, you may contact Solectek Technical Support for help.
  - Antenna misalignment: antennas must be aligned correctly to achieve maximum link distance.

- Radio interference: The radio activity in the environment is too strong and may interfere with your signals. You may try to determine the source by using a spectrum analyzer and a directional antenna.

2. "I can't access the SkyWay 7000 over Ethernet from my PC."

- Make sure the Ethernet connection is properly established.
- Make sure that the right IP address is used. Please refer to Section 2: **System Configuration** for setting up the right IP addresses for your PC and SKYWAY 7000 unit.

3. Can't access the Internet through the SkyWay 7000 unit.

- First, make sure that the wireless connection is established. Good RF conditions need to be established between the units' radios. MAC address of the other unit needs to be correctly typed in at both the base and client units.
- From a PC on the client unit side, ping the IP address of the SkyWay 7000. If this does not work, the wireless may still not be properly established or the LAN IP setting is not correctly set between the SkyWay 7000 and client.
- Ping a known IP address on the Internet, such as Yahoo's IP address, 66.218.71.81. (From the DOS prompt command line, type "ping 66.218.71.81"). If this does not work, you have a problem getting out to the Internet. Make sure that the IP setting is set correctly between the SKYWAY 7000 and the surrounding IP network. Check with your IT administrator or ISP to see if the Internet connection is up and running.
- If you can ping an Internet IP address, but still cannot browse the Internet, make sure the DNS is set correctly on your network. Check with your IT administrator or ISP for proper DNS setting for your wireless network.

## Appendix C

For your records please record following items about your unit and keep it safe in your records:

Username and Password:	
Encryption key:	



Information contained in this document is subject to change without notice. Solectek Corporation shall not be liable for errors contained herein or for incidental or consequential damage in connection with the furnishing, performance, or use of this material. Reproduction, adaptation, or translation without prior written permission is prohibited, except as allowed under the copyright laws.

Solectek Corporation makes no warranty of any kind with regard to this material, including, but not limited to, the implied warranties or merchantability and fitness for a particular purpose.

**NOTE: Changes or modifications not expressly approved by Solectek could void the user's authority to operate the equipment.**

SkyWay and Solectek are registered trademarks of Solectek Corporation. Windows is the trademark of Microsoft Corp.

Copyright 2005, Solectek Corp. All rights reserved.  
Part Number: 1347101  
Revision 2.0